

APPLICATION:

PRODUCT NAME:
GLASS FILLER VALVE WITH
SHORT SQUEEZE LEVER

JOB NAME:

_____ SPECIAL CONFIGURATION
CHECK BASE MODEL AND OPTIONS

QUANTITY:

ITEM NO.

MODEL:
 1704

OPTIONS OR MODIFICATIONS:
 OTHER _____

FEATURES

- GLASS FILLER VALVE
- * SPRAY NOZZLE THREADED INTO BODY
 - * BRONZE HANDLE - NOT PLASTIC - MEANS FULL "ON"
 - * BUILT-IN SPRAY HANDLE CLIP
 - * FITS ALL BRANDS

- SYSTEM LIMITS
- * TEMP: 40°F MIN. TO 140°F MAX.
 - * PRESSURE: 200 PSI MAX. STATIC

- SHIPPING WEIGHT
- * 1.5 LBS

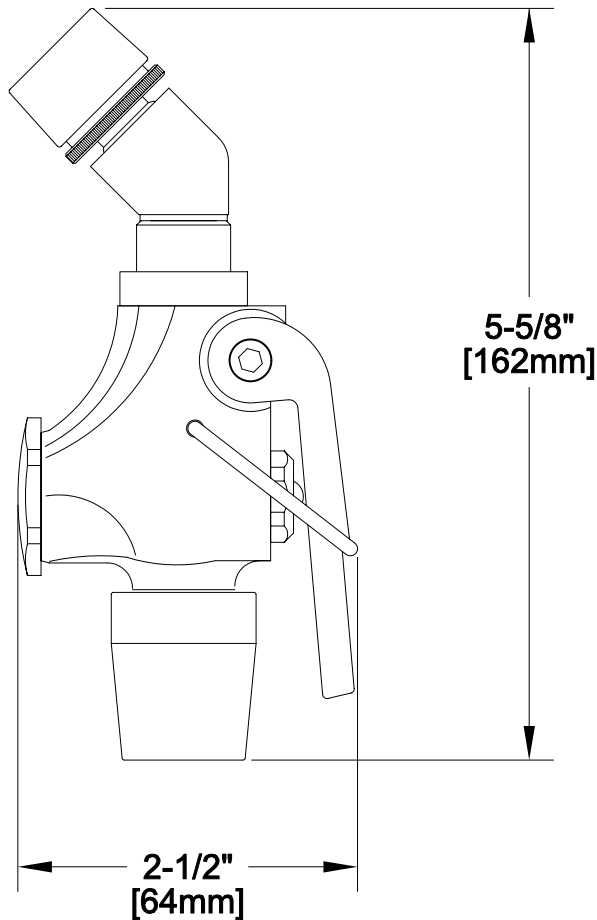

FISHER MANUFACTURING COMPANY
TOLL FREE: 800-421-6162 - FAX: 800-832-8238
information@fisher-mfg.com - www.fisher-mfg.com